

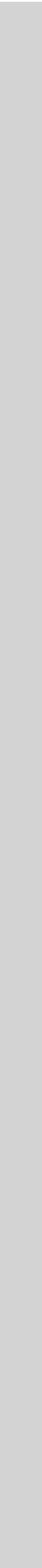

## HPLC SYSTEM S 600 SERIES

The *Sykam HPLC System S 600 Series* is intended for the ambitious analyst. The system configuration is highly variable and several upgrade options make this system suitable for the whole range of analytical applications.





# S 1130 HPLC PUMP SYSTEM

The **Sykam S 1130 HPLC Pump System** is a very flexible and powerful HPLC solvent delivery system. Its modular setup makes the **S 1130** one of the most

versatile pump systems on the market. The possible configurations include an Isocratic, Quaternary Gradient Pump or a Binary High-Pressure Gradient Pump.

## One Pump - Three Configurations

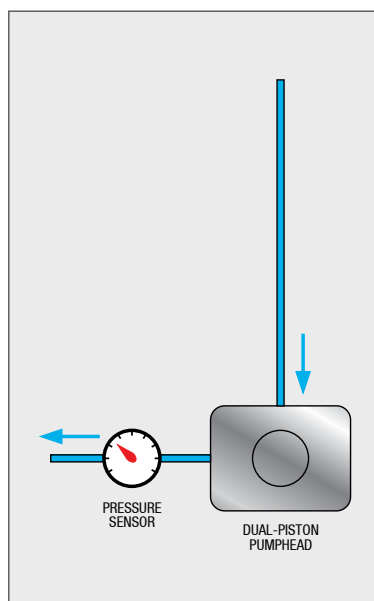

Figure: S 1130 Isocratic Flowchart

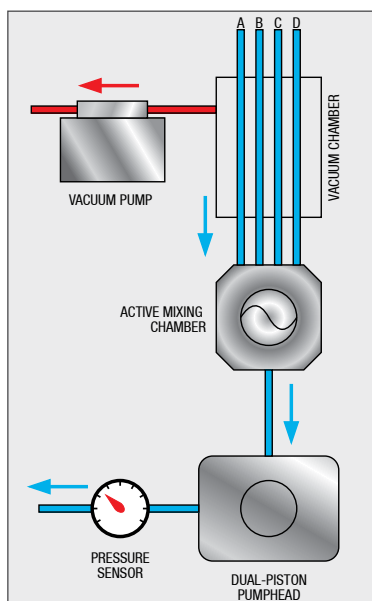

Figure: S 1130G LP Gradient Flowchart

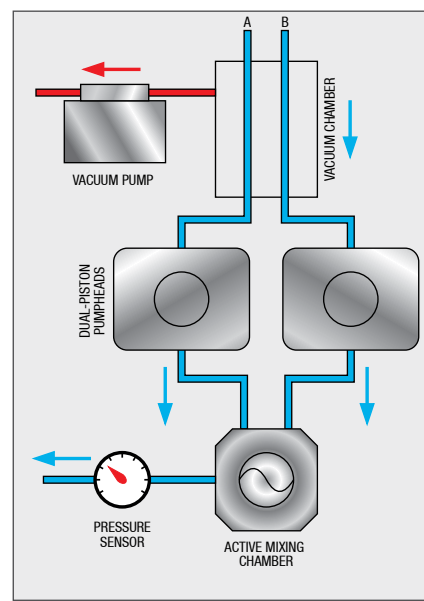

Figure: S 1132 HP Gradient Flowchart

## Stepper Motor

The **S 1130** is driven by a high-power stepper motor. The stepper motor has a much better resolution in the low-flow range than a conventional DC motor.

## Active Mixer

The **S 1130** low pressure and high pressure gradient module has an active mixer to achieve highly precise and accurate gradient results.

## Lubrication

The **S 1130** camshaft is constantly lubricated within a sealed chamber to guarantee long lifetime and low maintenance.

## Dual-Piston Pumphead

The **S 1130** pumps use a dual-piston pumphead for low pulsation. Together with electronic pressure compensation the S 1130 pumps are suitable for all analytical tasks in HPLC and GPC.

## Optional: Piston Backflushing

The **S 1130**'s pump head incorporates an optional active piston backflushing system; this system is interchangeable with old Sykam pumps and does not require an additional motor.

## Technical Specifications

<b>Wetted Materials:</b>	Stainless Steel / PEEK*, Teflon AF®, PVDF, Ceramics, Sapphire, Ruby
<b>Flow Rate:</b>	Programmable Micro: 0.001 - 4.000 ml/min Analytical: 0.001 - 10.000 ml/min Semi-Preparative: 0.1 - 40.000 ml/min
<b>Flow Accuracy:</b>	± 1.0 % 1.000 ml / min
<b>Flow Precision:</b>	± 0.1 % RSD 1.000 ml/min
<b>Pressure Range:</b>	0 – 40 MPa (0 – 6000 PSI) Semi-Preparative: 20 MPa (up to 20.000 ml/min); 10 MPa (up to 40.000 ml/min)
<b>Pressure Pulsation:</b>	typical < 0.1 MPa or < 1.0 %
<b>Compressibility Compensation:</b>	user-adjustable for different solvents
<b>Dimensions: (W x H x D)</b>	396 x 165 x 478 mm
<b>Power Supply:</b>	100 - 250 ~V (47 - 63 Hz)

\* depending on configuration

## S 1130G Quaternary Gradient Pump

<b>Vacuum Degassing:</b>	<i>optional:</i> < 20% dissolved gases remaining in water @ 1.000 ml/min
<b>Gradient Range:</b>	0.0 – 100.0 %, 4 channels
<b>Gradient Accuracy:</b>	< 0.50 %
<b>Gradient Mixing:</b>	Active
<b>Mixer Volume:</b>	adjustable: 10 – 500 µl

## S 1132 Binary Gradient Pump

<b>Vacuum Degassing:</b>	<i>optional:</i> < 20% dissolved gases remaining in water @ 1.000 ml/min
<b>Gradient Range:</b>	0.0 – 100.0 %, 2 channels
<b>Gradient Accuracy:</b>	< 0.50 %
<b>Gradient Mixing:</b>	Active
<b>Mixer Volume:</b>	adjustable: 10 – 500 µl



## S 1130 Configurations

### S 1130 Isocratic HPLC Pump

The **S 1130 Isocratic Pump** is a robust, low-pulsation solvent delivery system. The pumphead is easily accessible from the front panel to make routine maintenance, like changing pump seals, easy and fast. The system is available with Micro, Analytical or Semi-Preparative pumphead in Stainless Steel or PEEK.

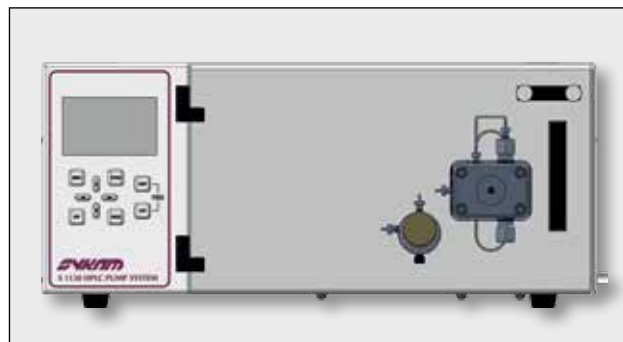

### S 1130G Low-Pressure Quaternary Gradient Pump

The **S 1130G Low-Pressure Quaternary Gradient Pump** incorporates an active low pressure mixer with adjustable mixing volume. The mixing chamber volume can be freely adjusted. An optional integrated vacuum degasser removes dissolved gases in the eluents and prevents air bubbles in the system. The system is available with Micro, Analytical or Semi-Preparative pumphead in Stainless Steel or PEEK.

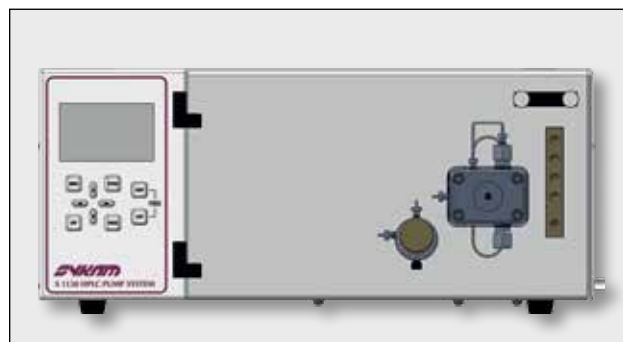

### S 1132 High-Pressure Binary Gradient Pump

The **S 1132 High-Pressure Binary Gradient Pump** incorporates two pump systems with active high pressure mixer with adjustable chamber volume. An optional integrated vacuum degasser removes dissolved gases in the eluents and prevents air bubbles in the system. The system is available with Micro, Analytical or Semi-Preparative pumpheads in Stainless Steel or PEEK.

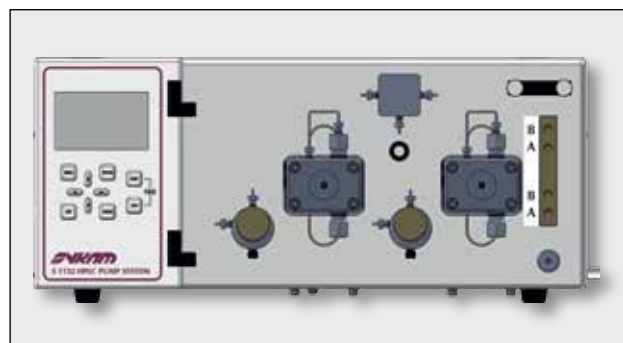

# S 5300 SAMPLE INJECTOR SYSTEM

The **Sykam S 5300 Sample Injector System** is a very flexible and powerful HPLC autosampler with excellent reproducibility and linearity properties. Variable vial racks and adaptors for microtiter plates as well as a multitude of firmware options make this system highly adaptable and suitable for any analytical application.

## Robust Design

### Durable X/Y/Z-Sampling

The **S 5300 Sample Injector System** features a mechanically durable X/Y/Z-Sampling-Mechanic designed for long life operation. The self-lubricating bearings keep the routine maintenance at a minimum and avoid troubles caused by dusty environments. High precision stepper motors drive the X/Y axis for accurate positioning. Microstepping mode enables a high resolution for the syringe dosing and vial positioning.

### Dual-Needle Design

The Dual-Needle design of the **S 5300 Sample Injector System** avoids system blockages due to septum particles injected into the system. The ventilation needle pierces the septum before the injection needle moves into the sample vial (see figure on the right). As the more fragile injection needle does not need to pierce the vial septum, stronger vial caps or plastic vials can be used without problems.



### Accessibility

The injection valve with sample loop and injection port can be accessed directly from the instrument front without removing any protective covers. The dosing syringe can be accessed from the side of the instrument through a hinged glass panel. The exchange of the syringe can be done without the requirement of any tools.

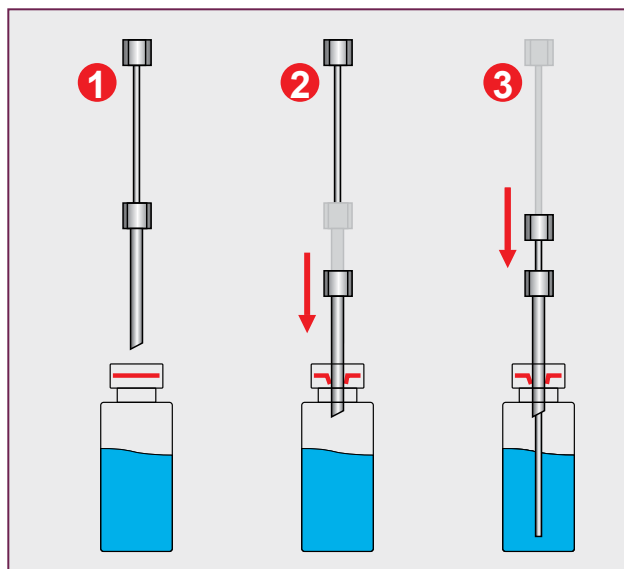

Figure: Dual-Needle Injection

# Precision & Modularity

## Performance

The **Sykam S 5300 Sample Injector System** offers multiple injection modes depending on application and sample needs. Besides fixed loop overfilling and variable volume injection the instrument offers a **Zero-Waste** injection mode for injecting very small sample amounts by moving the sample into the middle of the sample loop.

Linearity and injection precision can be optimized for any volume by different sample loops and syringe sizes.

## Modular Options

The modular nature of the **Sykam S 5300 Sample Injector System** offers the possibility to “*just buy what you need*”. Modular options include sample heating/cooling for any sensitive sample material and derivatization for automatized pre-column derivatization tasks from reagent derivatization to automatic sample dilution.

## Technical Specifications

<b>Wetted Materials:</b>	Stainless Steel / PEEK*, PPS, PVDF
<b>Sample Capacity:</b>	120 (1.5 ml), 192 (microtiter plates)
<b>Injection Volume:</b>	Programmable 0.1 - 999.9 µl
<b>Sample Heating/Cooling:</b>	<i>optional:</i> +4 – +60 °C
<b>Injection Precision:</b>	< 0.5 % Variable Volume Injection (10 µl; typically ~0.25 %)
<b>Linearity:</b>	Correlation Factor > 0.999 (10 µl injection volume, 500 µl Syringe)
<b>Carry Over:</b>	< 0.05 % with wash program
<b>Dimensions:</b> (W x H x D)	396 x 275 x 478 mm
<b>Power Supply:</b>	100 - 250 ~V (47 - 63 Hz)

\* depending on configuration

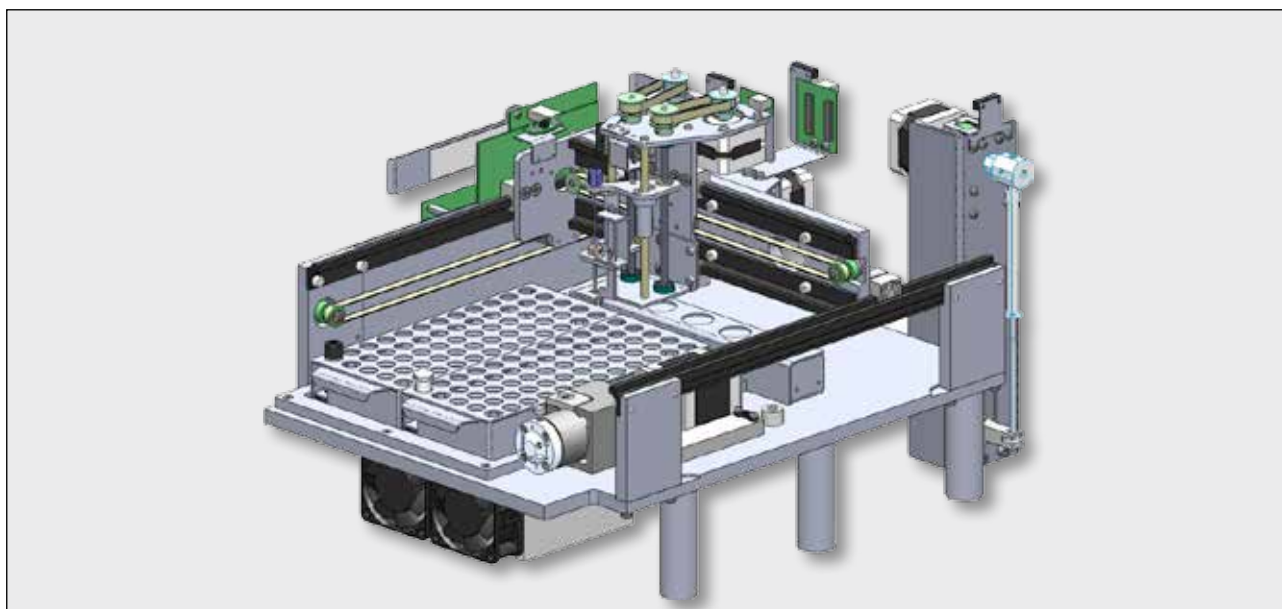

# S 3250 UV/VIS DETECTOR

The **Sykam S 3250 UV/Vis Detector** is a variable wavelength UV/Vis detector for routine analysis and sophisticated research. The dual lamp design offers a wavelength range of 190 – 800 nm with a low baseline noise. The front-accessible flowcell can be easily exchanged, as well as the lamps which are accessible through a side panel in the instrument housing.

## Integrated Wavelength Program

The **S 3250 UV/Vis Detector** features a wavelength program to change the selected wavelength over time. With this feature the optimum wavelength can be selected for each analyzed substance according to its retention time.

## Integrated Peak Detector

The integrated Peak Detector works as a basic fraction collector. The peak detection level can be freely programmed for peak start and peak end to enhance the collection purity. An integrated 24V output for switching a solenoid valve is used for the fraction collection, which is automatically operated with a selectable time delay.

## Optional – Dual-Wavelength

The **S 3250 UV/Vis Detector** is available with an optional second wavelength. This feature enhances the Wavelength Program feature that you can measure 2 different wavelengths at the same time. A second D/A converter output comes with this option to keep the system flexible to be used with any data acquisition software available.



## Optional – Online-Scan

Another option for the **S 3250 UV/Vis Detector** is the Online Scan. With the Online Scan whole spectrum information can be gathered at a certain time. This scan information is stored internally and can be accessed at any time. The Online Scan is a good alternative to a full UV PDA detector.

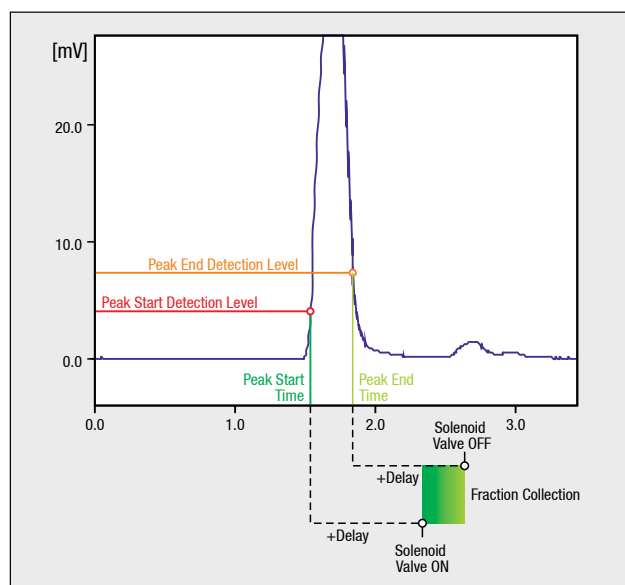

Figure: S 3250 Peak Detector

## Technical Specifications

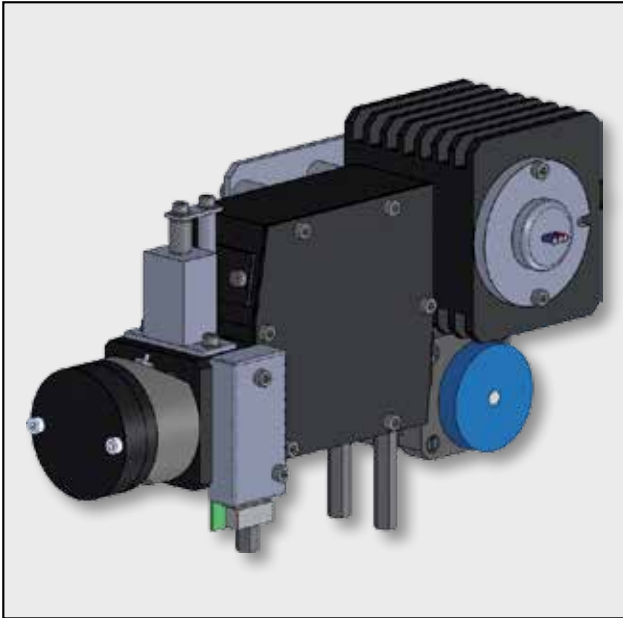

Figure: S 3250 Optical Module

<b>Wetted Materials:</b>	Stainless Steel / PEEK*
<b>Baseline Noise:</b>	$\pm 1 \times 10^{-5}$ AU (@240 nm, 2 sec. Risetime)
<b>Baseline Drift:</b>	$< 3 \times 10^{-4}$ AU/h
<b>Wavelength Range:</b>	190 – 800 nm
<b>Wavelength Accuracy:</b>	$\pm 2$ nm
<b>Linearity:</b>	$> 2.0$ AU
<b>Light Source</b>	Deuterium Lamp, Tungsten Lamp
<b>Wavelength Program:</b>	Programmable, 10 steps
<b>Analog Output:</b>	1x 1 V ( <i>optional</i> : 2x 1V)
<b>Control Features:</b>	Internal Peak Detector with +24 V solenoid switching output.
<b>Dimensions: (W x H x D)</b>	396 x 165 x 478 mm
<b>Power Supply:</b>	100 - 250 ~V (47 - 63 Hz)

\* depending on configuration

## Principle of Operation

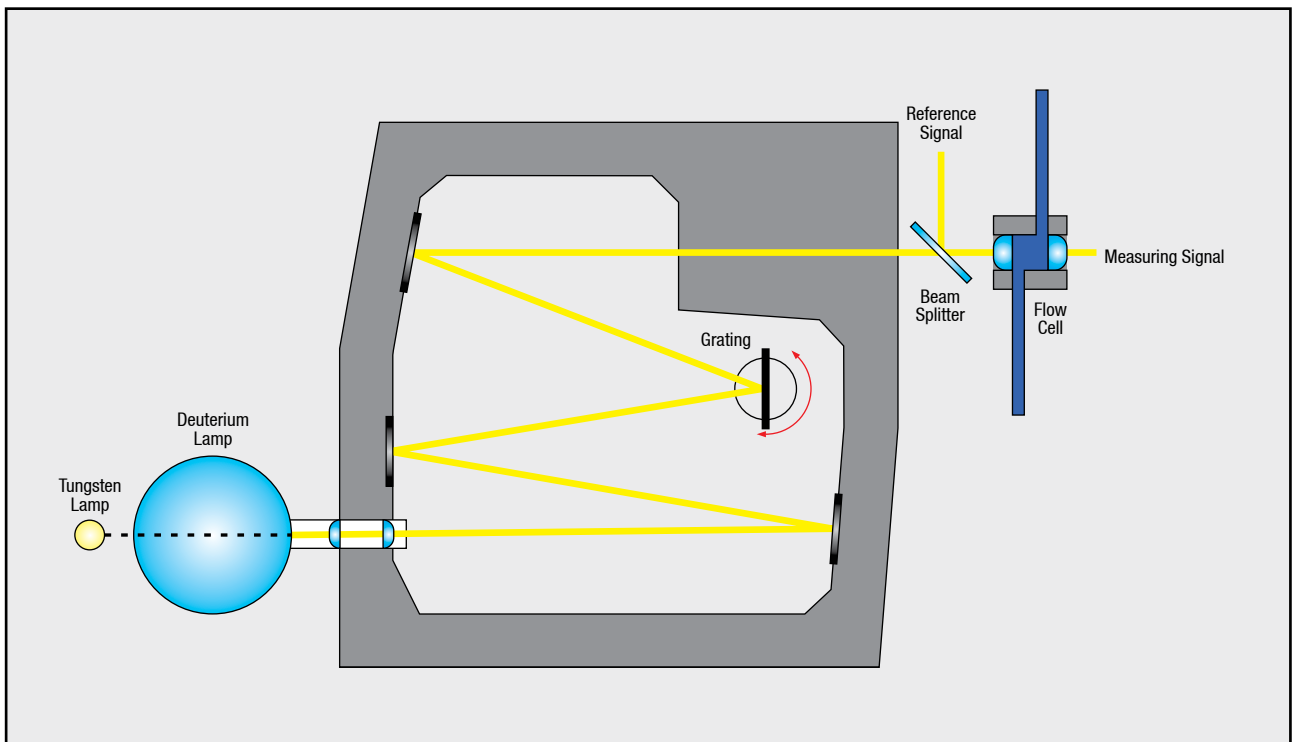

Figure: Principle of Operation

# S 3350 PDA DETECTOR

The **Sykam S 3350 UV/Vis Detector** is a photo-diode-array (PDA) detector for routine analysis and sophisticated research. The dual lamp design offers a wavelength range of 190 – 720 nm (256 Diodes)

or 190 - 1015nm (1024 diodes) with a low baseline noise. The front-accessible flowcell can easily be exchanged, as can be the lamps which are accessible through a side panel in the instrument housing.



## 4-Channel UV Detector

The **S 3350 PDA Detector** features 4-Wavelength channels to measure chromatograms at 4 different wavelengths at the same time. With this feature the optimum wavelength can be selected for each analyzed substance.

## Integrated Peak Detector

The integrated Peak Detector works as a basic fraction collector. The peak detection level can be freely programmed for peak start and peak end to enhance the

collection purity. An integrated 24V output for switching a solenoid valve is used for the fraction collection, which is automatically operated with a selectable time delay.

## Optional – Analog Output

The **S 3350 PDA Detector** is available with an optional 4-Channel analog output. This D/A converter output option is offered to keep the system flexible to be used with any data acquisition software available.

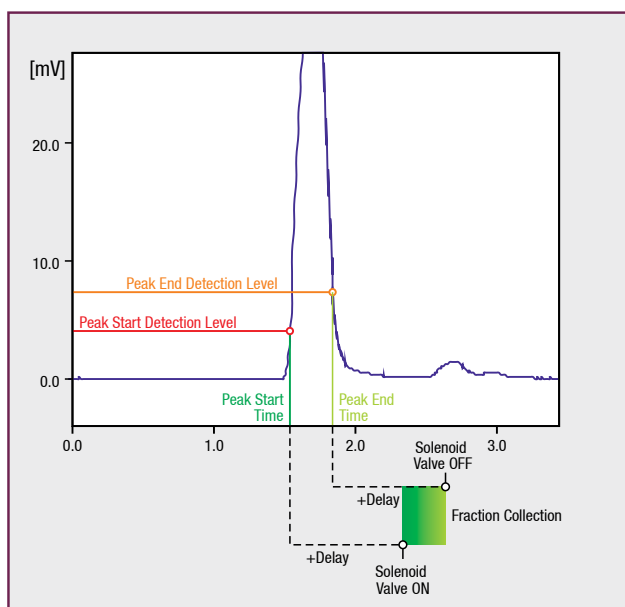

Figure: S 3350 Peak Detector

## Technical Specifications\*

<b>Wetted Materials:</b>	Stainless Steel / PEEK*, Teflon, Glas
<b>Baseline Noise:</b>	$\pm 1 \times 10^{-5}$ AU (@240 nm, 1 sec. Risetime)
<b>Baseline Drift:</b>	$<3 \times 10^{-4}$ AU/h
<b>Number of Diodes:</b>	256 or 1024
<b>Wavelength Range:</b>	190 – 720 nm (256 Diodes) 190 – 1015 nm (1024 Diodes)
<b>Wavelength Accuracy:</b>	0.5 nm (256 Diodes); 0.3 nm (1024 Diodes)
<b>Mean Pixel Pitch:</b>	2.2 nm (256 Diodes), 0.8 nm (1024 Diodes)
<b>Resolution (<math>\lambda</math> FWHM):</b>	7 nm (256 Diodes), 3 nm (1024 Diodes)
<b>Linearity:</b>	$> 2.0$ AU
<b>Light Source</b>	Deuterium Lamp, Tungsten Lamp
<b>Wavelength Program:</b>	Programmable, 10 steps
<b>Analog Output:</b>	- ( <i>optional</i> : 4x 1V)
<b>Data Rate:</b>	1 Hz - 100 Hz
<b>Control Features:</b>	Internal Peak Detector with +24 V solenoid switching output.
<b>Dimensions:</b>	396 x 165 x 478 mm
<b>(W x H x D)</b>	
<b>Power Supply:</b>	100 - 250 ~V (47 - 63 Hz)

\* depending on configuration



Figure: S 3350 Optical Module

# S 3590 REFRACTIVE INDEX DETECTOR



The **Sykam S 3590 Refractive Index Detector** offers the sensitivity, stability and reproducibility required for optimal RI detection.

The thermal isolated optic with a countercurrent heat exchanger and with its programmable temperature control, results in an extremely stable baseline and an optimal Signal /Noise ratio.

The **Sykam S 3590 Refractive Index Detector** provide autopurge and autozero capabilities, as well as RS232 communication to acquire data directly without using any external signal interface.

**Sykam S 3590 Refractive Index Detectors** are available for:

- micro
- analytical
- semipreparative mode

## Technical Specifications\*

	Micro	Analytical	Semi-Preparative
<b>Detection Method:</b>		Deflection	
<b>Refractive Index Range:</b>		1.00 to 1.75	
<b>Flow Rate:</b>	0.2 - 3.0 ml/min	0.2 - 3.0 ml/min	1 - 50 ml/min
<b>Cell Volume:</b>	4 $\mu$ l, 45° angle	9 $\mu$ l, 45° angle	7 $\mu$ l, 5° angle
<b>Flow Cell Pressure:</b>	6 kg/cm <sup>2</sup>		
<b>Dead Volume:</b>	6 $\mu$ l	24 $\mu$ l	88 or 353 $\mu$ l
<b>Linearity Range:</b>	0 - 500 $\mu$ RIU	0 - 1000 $\mu$ RIU	0 - 20000 $\mu$ RIU
<b>Noise Level:</b>	10 x 10 <sup>-9</sup> RIU	5 x 10 <sup>-9</sup> RIU	10 x 10 <sup>-8</sup> RIU
<b>Drift with 1ml H<sub>2</sub>O/min</b>	< 1mv/hour	< 1mv/hour	< 1mv/hour
<b>Integrator Output:</b>	$\pm$ 1 V		
<b>Recorder Output:</b>	$\pm$ 10 mV/ 100 mV/ 1 V		
<b>Recorder Offset:</b>	0 mV/ 10 mV/ 100 mV		
<b>Recorder Range:</b>	8 steps (1:8) - 16:1)		
<b>Digital Interface:</b>	RS232, Purge, Autozero, Start, Stop, DataOut: 1 Hz, 10 Hz		
<b>Digital Output:</b>	TTL: Intensity Alarm		
<b>Digital Input:</b>	TTL: Purge, Autozero, Start, Marker		
<b>Temperature Setting:</b>	Ambient, 35°C to 55°C in 1 °C steps, Thermal Fuse 75°C		
<b>Time Constant:</b>	RAW (0.0 sec.), Fast (0.4 sec.), Medium (0.8 sec.), Slow (1.2 sec.)		
<b>Weight:</b>	13 kg		
<b>Dimensions: (W x H x D)</b>	396 x 165 x 478 mm		
<b>Power Supply:</b>	100-120/220-240 ~V (50/60 Hz), 50 VA		

\* All technical specifications may be subject to change.

# S 4115 COLUMN OVEN

The **Sykam S 4115 Column Oven** is a contact heat transfer oven for high temperature stability and accuracy. The columns are mounted inside the column oven in optimized column holder which enclose the

complete column to get the best temperature transfer between the heater and the column. Up to two columns (max. length 250 mm) can be mounted at the same time (max. O.D. 8 mm).



## Heating

The **Sykam S 4115 Column Oven** standard version features a high temperature controller for stable column temperatures of +30°C up to +100°C. The temperature accuracy is within 0.1 °C.

## Heating/Cooling

The **Sykam S 4115 Column Oven** is also available with active Heating/Cooling with Peltier technique. The temperature range is +5°C up to +100°C. The Heating/Cooling unit uses the same efficient controller as the basic version with temperature accuracy better than 0.1 °C.

## Temperature Time Program

The Heating/Cooling variant offers an optional Temperature Time Program for stand-alone operation.

## Integrated Valve

The **Sykam S 4115 Column Oven** offers the option to include an automatic switching valve of the **Sykam S 6000 Valve Series**, for example the **S 6070 Column Selection Valve**, but all **S 6000** Valves can be integrated.

## Leakage Sensor

The **S 4115 Column Oven** offers a high sensitive Leakage Sensor which detects the vapors of organic solvents.

## Temperature Fuse

Besides a Leakage Sensor the **S 4115** offers a temperature fuse which shuts down the unit when the temperature becomes too high, because of an electronic defect.

## Technical Specifications

<b>Wetted Materials:</b>	Stainless Steel / PEEK <sup>1</sup> , PPS <sup>1</sup>
<b>Temperature Range:</b>	+30°C – +100°C (min.: ambient +5 °C) <i>optional:</i> +5°C – +100 °C (Peltier) <sup>2</sup>
<b>Temperature Accuracy:</b>	< 0.1 °C
<b>Switching Valve:</b>	<i>optional:</i> any <b>S 6000</b> Series Valve
<b>Temperature Program:</b>	optional with Heating/Cooling (Peltier)
<b>Safety Features:</b>	Temperature Fuse; Leakage Sensor
<b>Dimensions: (W x H x D)</b>	396 x 165 x 478 mm
<b>Power Supply:</b>	100 - 250 ~V (47 - 63 Hz)

<sup>1</sup> Switching Valve: depending on configuration

<sup>2</sup> Temperature range at 20°C ambient

## OEM Options

The **Sykam S 4115 Column Oven** itself is available as a complete OEM instrument. Please contact us for any further information on OEM modules.



Figure: S 4115 Column Compartment w. Switching Valve S 6010

# S 4120 COLUMN OVEN

The **Sykam S 4120 Column Oven** is a contact heat transfer oven for high temperature stability and accuracy. The columns are mounted inside the column oven in optimized column holder which enclose the

complete column to get the best temperature transfer between the heater and the column. Up to three 350mm columns can be mounted at the same time.

## Heating

The **Sykam S 4120 Column Oven** standard version features a high temperature controller for stable column temperatures of +30°C up to +150°C. The temperature accuracy is within 0.1 °C.

## Heating/Cooling

The **Sykam S 4120 Column Oven** is also available with active Heating/Cooling with Peltier technique. The temperature range is +5°C up to +100°C. The Heating/Cooling unit uses the same efficient controller as the basic version with temperature accuracy better than 0.1 °C.

## Temperature Time Program

The Heating/Cooling variant offers an optional Temperature Time Program for stand-alone operation.

## Integrated Valve

The **Sykam S 4120 Column Oven** offers the option to include an automatic switching valve of the **Sykam S 6000 Valve Series**, for example the **S 6070 Column Selection Valve**, but all **S 6000** Valves can be integrated.



## Leakage Sensor

The **S 4120 Column Oven** offers a high sensitive Leakage Sensor which detects the vapors of organic solvents.

## Temperature Fuse

Besides a Leakage Sensor the **S 4120** offers a temperature fuse which shuts down the unit when the temperature becomes too high, because of an electronic defect.

## OEM Options

The **Sykam S 4120 Column Oven** itself is available as a complete OEM instrument. Please contact us for any further information on OEM modules.

## Technical Specifications

<b>Wetted Materials:</b>	Stainless Steel / PEEK <sup>1</sup> , PPS <sup>1</sup>
<b>Temperature Range:</b>	+30°C – +150°C (min.: ambient +5 °C) <i>optional:</i> +5°C – +100 °C (Peltier) <sup>2</sup>
<b>Temperature Accuracy:</b>	< 0.1 °C
<b>Switching Valve:</b>	<i>optional:</i> any <b>S 6000</b> Series Valve
<b>Temperature Program:</b>	optional with Heating/Cooling (Peltier)
<b>Safety Features:</b>	Temperature Fuse; Leakage Sensor
<b>Dimensions: (W x H x D)</b>	183 x 566 x 270 mm
<b>Power Supply:</b>	100 - 250 ~V (47 - 63 Hz)

<sup>1</sup> Switching Valve: depending on configuration

<sup>2</sup> Temperature range at 20°C ambient



Figure: S 4120 Column Compartment

# S 7515 VACUUM DEGASSER

The **Sykam S 7515 Vacuum Degasser** is an online degasser system with high efficiency. Dissolved gases are removed from the solvents by applying vacuum to a semi-permeable membrane.



## High Efficiency

The high efficient Teflon-AF® capillary has a much higher efficiency than a normal Teflon capillary of similar size. This allows the usage of a smaller length of capillary to reduce the dead volume of the system considerably.

## 2 Operation Modes

The **S 7515** can be run either with constant speed or in Hysteresis Mode, which switches the vacuum pump on or off.

## 5-Year Membrane Warranty

The **S 7515** vacuum pump uses a membrane for creating the vacuum. This membrane is made of a specific Teflon material specifically designed for fast movements. **Sykam** offers a 5-year warranty on the lifetime of this membrane.

## Multi-Channel

The **S 7515 Vacuum Degasser** is available as 1-Channel, 2-Channel, 3-Channel, or 4-Channel version. Each solvent channel can be used for a different solvent. Several channels can be used in series to increase the efficiency even more.

## OEM

**Sykam** offers this instrument as an OEM product to any interested party, even for small numbers. Besides the complete instrument **Sykam** also offers the vacuum pump and vacuum chambers as OEM modules.

## Working Principle

The solvent flows through a short length of Teflon AF<sup>®</sup> capillary inside a sealed chamber. This chamber (vacuum chamber) is completely sealed to the environment and vacuum is applied with a pump. Due to this vacuum any dissolved gases in the solvent running through the inner capillary are removed through its semi-permeable membrane wall. The high efficiency of the Teflon AF<sup>®</sup> material allows the usage of a very short length of capillary inside the vacuum chamber.

## Specifications

<b>Wetted Materials:</b>	Teflon AF <sup>®</sup> , Teflon, Stainless Steel, Aluminium, EPDM
<b>Degassing Capacity:</b>	< 20% dissolved gases remaining in water at 1.0 ml/min
<b>Volume / Channel:</b>	< 500µl
<b>Dimensions: (W x H x D)</b>	125 x 167 x 270 mm
<b>Weight:</b>	3.2 kg
<b>Power Supply:</b>	100 - 250 ~V (47 - 63 Hz)

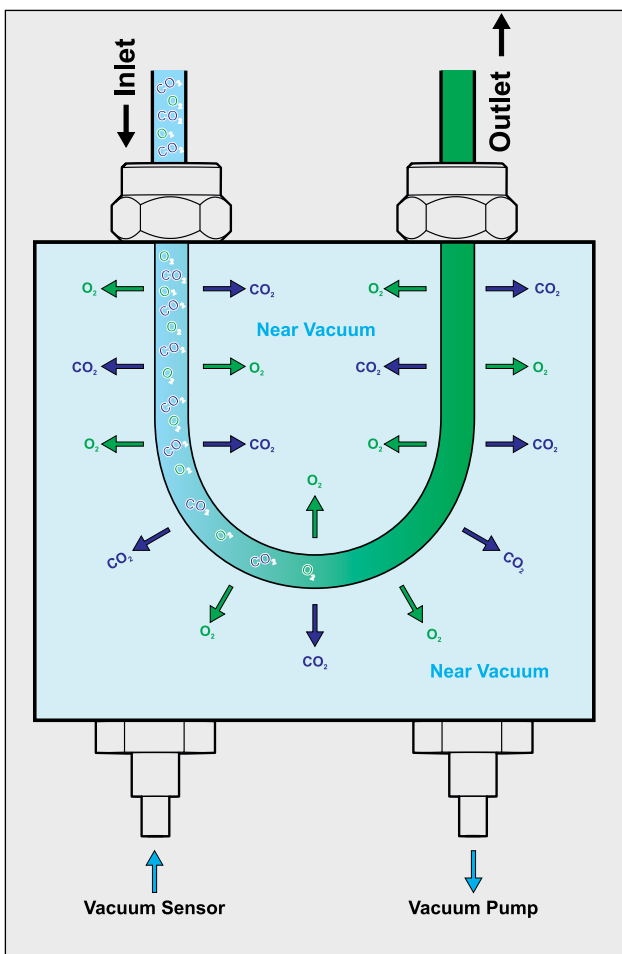

# Order Information

## S 1130 HPLC Pump

### Isocratic Version

Catalog No.	Instrument Description	Notes
S000051	S 1130 HPLC Pump, isocratic	stainless steel, analytical
S000052	S 1130 HPLC Pump, isocratic	stainless steel, micro
S000053	S 1130 HPLC Pump, isocratic	stainless steel, semi-prep.
S000054	S 1130 HPLC Pump, isocratic	Peek, analytical
S000055	S 1130 HPLC Pump, isocratic	Peek, micro
S000056	S 1130 HPLC Pump, isocratic	Peek, semi-prep.
S003495	S 1130 HPLC Pump, isocratic	Stainless steel, analytical, max. 600bar
S003496	S 1130 HPLC Pump, isocratic	Stainless steel, micro, max. 600bar
S000043	Upgrade: Active Piston Flushing	actually only available with stainless steel, analytical pump head

### Quaternary Gradient Version

Catalog No.	Instrument Description	Notes
S000057	S 1130 HPLC Pump, Quaternary Gradient	stainless steel, analytical
S000058	S 1130 HPLC Pump, Quaternary Gradient	stainless steel, micro
S000059	S 1130 HPLC Pump, Quaternary Gradient	stainless steel, semi-prep.
S000060	S 1130 HPLC Pump, Quaternary Gradient	Peek, analytical
S000061	S 1130 HPLC Pump, Quaternary Gradient	Peek, micro
S000062	S 1130 HPLC Pump, Quaternary Gradient	Peek, semi-prep.
S003497	S 1130 HP HPLC Pump, Quaternary Gradient	stainless steel, analytical, max. 600bar
S003501	S 1130 HP HPLC Pump, Quaternary Gradient	stainless steel, micro, max. 600bar
S000050	Integrated 4-Channel Vacuum Degasser	
S000043	Upgrade: Active Piston Flushing	actually only available in combination with stainless steel, analytical pump head

## S 1132 Binary HPLC Pump

Catalog No.	Instrument Description	Notes
S000063	S 1132 Binary HPLC Pump	stainless steel, analytical
S000064	S 1132 Binary HPLC Pump	stainless steel, micro
S000066	S 1132 Binary HPLC Pump	Peek, analytical
S000067	S 1132 Binary HPLC Pump	Peek, micro
S000065	S 1132 Binary HPLC Pump	stainless steel, semi-prep.
S000068	S 1132 Binary HPLC Pump	Peek, semi-prep.
S000069	Integrated 2-Channel Vacuum Degasser	
S000070	Integrated High Pressure mixer	stainless steel
S000071	Integrated High Pressure mixer	PEEK (150 - 200 bar)
S000043	Upgrade: Active Piston Flushing	per each pumphead actually only available in combination with stainless steel, analytical pump head

## S 3250 UV/Vis Detector

Catalog No.	Instrument Description	Notes
S000172	S 3250 UV/Vis Detector, 1-Channel	1-Channel
S000193	S 3250 UV/Vis Detector, 2-Channel	2-Channel
S000196	S 3250 UV/Vis Detector, 1-Channel, Scan	1-Channel & Scan-Option
S000173	S 3250 Flowcell	stainless steel, analytical
S000203	S 3250 Flowcell	Peek, analytical
S000204	S 3250 Flowcell	Peek, preparative
S000205	S 3250 Flowcell	stainless steel, preparative
S001741	S 3250 Flowcell	stainless steel, micro

## S 3350 PDA Detector

Catalog No.	Instrument Description	Notes
S000162	S 3350 PDA-UV/Vis-Detector	256-Diodes
S000163	S 3350 PDA-UV/Vis-Detector	1024- Diodes
S000169	S 3350 Flowcell	stainless steel, analytical
S000517	S 3350 Flowcell	Peek, analytical
S002021	S 3350 Flowcell	Stainless steel, preparative
S004370	S 3350 Flowcell	Peek, preparative
S004371	S 3350 Flowcell	Stainless steel, micro
S004372	S 3350 Flowcell	Peek, micro

## S 3590 Refractive Index (RI) Detector

Catalog No.	Instrument Description	Notes
S004368	S 3590 RI Detector	Stainless steel, micro
S000166	S 3590 RI Detector	Stainless steel, analytical
S004369	S 3590 RI Detector	Stainless steel, semi preparative

## S 4115 Column Oven

Catalog No.	Instrument Description	Notes
S000109	S 4115 Column Oven	Heating only (30°C - 100°C)1
S000110	S 4115 Column Oven	Heating/Cooling (5°C - 100°C)2
S004375	S 4115 Column Oven Temperature Programm (Option)	Requires Catalog No. S000110
S000838	S 4115 Column Oven Accessory	Column Holder #1 (diamter 8 mm, length 100 mm up to 250 mm) ***
S000839	S 4115 Column Oven Accessory	Column Holder #2 (dimeter 9 – 13 mm, length up to 250 mm) ***
S004373	Upgrade: Integrated Switching Valve	Motor driven, without valve (has to be ordered separately)

**Notes: 1) min. ambient +5°C  
2) at +20°C ambient  
\*\*\* Oven comes by default with one  
Column Holder #1 (No. S00838)  
Other Column Holders are available on request !**

## S 4120 Column Oven

Catalog No.	Instrument Description	Notes
S000084	S 4120 Column Oven	Heating only (30°C - 150°C) <sup>1</sup>
S000103	S 4120 Column Oven	Heating/Cooling (5°C - 100°) <sup>2</sup>
S004367	S 4120 Column Oven Temperature Programm (Option)	Requires Catalog No. S000103
S000838	S 4120 Column Oven Accessory	Column Holder #1 (diamter 8 mm, length 100 mm up to 250 mm) ***
S000839	S 4120 Column Oven Accessory	Column Holder #2 (dimeter 9 – 13 mm, length up to 250 mm) ***
S004374	S 4120 Column Oven Accessory	Column Holder (dimeter 9 – 13 mm, length up to 300 mm) ***
S004373	Upgrade: Integrated Switching Valve	Motor driven, without valve (has to be ordered separately) <b>Notes: 1) min. ambient +5°C 2) at +20°C ambient</b> *** comes by default with one Column Holder #1 (No. S00838) Other Column Holders are available on request !

## S 5300 Sample Injector

Catalog No.	Instrument Description	Notes
S000082	S 5300 Sample Injector System	stainless steel, fix volume, 20 µl Sample Loop
S003330	S 5300 Sample Injector System	Peek Injection Valve, fix volume, 20 µl Sample Loop
S000083	Upgrade: Variable Volume	100 µl Sample Loop
S000161	Upgrade: Derivatisation	
S000177	Upgrade: Heating/Cooling	Heating/Cooling (5°C - 60°) (1) Notes: 1) at +20°C ambient

## S 600 Solvent Organizer

Catalog No.	Instrument Description	Notes
S000074	S 600 Reagent Organizer	Inert plastic tray with: 4 bottles (1000 ml, clear glass)
S004068	S 600 Reagent Organizer (Isocratic System)	Inert Plastic tray with 1 bottle (1000 ml, clear glas)
S000075	S 600 Reagent Organizer Prep.	Inert plastic tray with: 2 bottles (1000 ml, clear glass) & 2 bottles (2000ml, clear glas)
S000201	S 600 Reagent Organizer Binary	Inert plastic tray with: 2 bottles (1000 ml, clear glass)
S000202	S 600 Reagent Organizer Binary, Prep.	Inert plastic tray with: 2 bottles (2000 ml, clear glass)

## S 7515 Degasser

Catalog No.	Instrument Description	Notes
S000119	S 7515 Vacuum Degasser	1-Channel, stainless steel
S002871	S 7515 Vacuum Degasser	1-Channel, metallfree
S000120	S 7515 Vacuum Degasser	2-Channel, stainless steel
S000414	S 7515 Vacuum Degasser	2-Channel, metallfree
S000121	S 7515 Vacuum Degasser	3-Channel, stainless steel
S004366	S 7515 Vacuum Degasser	3-Channel, metallfree
S000122	S 7515 Vacuum Degasser	4-Channel, stainless steel
S004367	S 7515 Vacuum Degasser	4-Channel, metallfree

# SYKAM PRODUCTS

## S 500 Series HPLC Systems



## S 150 Ion Chromatography System



## S 433 Amino Acid Analyzer



## S 6000 Valve Series

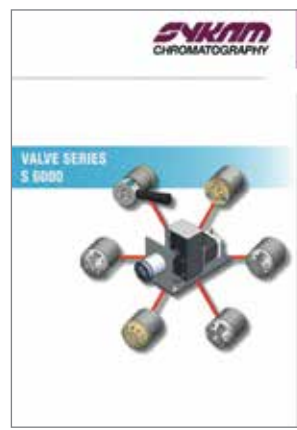

## Sykam OEM Modules



## S 6800 LP Valve Series

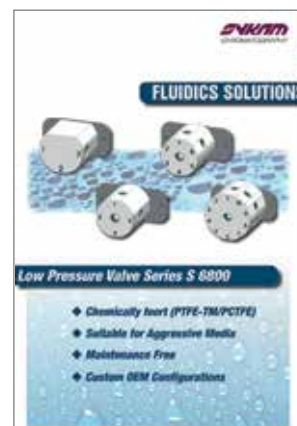

## **Sykam GmbH**

Systeme & Komponenten analytischer Meßtechnik

Gewerbering 15  
86922 Eresing  
Germany

Tel.: +49 (0) 8193 9382 - 0  
FAX: +49 (0) 8193 9382 - 20  
E-Mail: [info@sykam.com](mailto:info@sykam.com)  
Web: <http://www.sykam.com>